

# **Scaffold Depot**

---



---

## RING SYSTEM TECHNICAL MANUAL

---

### **Head Office**

#4 9659 192nd Street  
Surrey BC, Canada V4N 4C7  
Phone (604) 513-9222  
Fax (604) 513-9292

### **Edmonton Office**

7320 68 Avenue  
Edmonton AB, T6B 0A1  
Phone (780) 485-0934 | Toll Free: 1-888-595-6111  
Fax (780) 485-0359

**TOLL FREE 1-888-595-6111**  
**[www.scaffolddepot.com](http://www.scaffolddepot.com)**

---

## SD Ring System Scaffold Technical Manual

SD Ring System Scaffolding is a modular scaffold system that incorporates the use of vertical standards, 8- position rosettes, horizontal ledgers, and diagonal braces. This manual is intended to ensure erectors construct scaffolding safely and efficiently. For more complex structures, always consult your engineer or technical services department. Additional bracing or tie-ins are often required depending on intended loads to be supported by the scaffolding, wind loads, and flying of towers.

Scaffolding regulations may vary depending on your area. Always ensure all local codes are met when erecting.

Erection, altering, or dismantling of SD Ring System Scaffold should only be carried out by or under the supervision of a Competent Person, who is familiar with the component specifications and workplace safety regulations. Serious injury or death can result from the failure to familiarize yourself, and comply with all applicable safety requirements and regulations when erecting, using, or dismantling SD Ring System Scaffold.

Damaged components should never be used when erecting scaffolding. The condition of all parts should be inspected prior to installation, and damaged or worn parts should be returned to be repaired or destroyed. Of primary importance in any project is safety. Working directly with our customers, Scaffold Depot has developed a commitment to provide safe, durable, quality products that meet all applicable industry regulations and standards.

**This manual is subject to revision and updating.**

**Please contact Scaffold Depot to ensure you are using the most recent version of this manual.**

---

---

Table of contents

Standards ..... 04

Ledgers ..... 05

Truss Ledgers ..... 06

Lattice Girders ..... 07

Bay Braces ..... 08

Stair Stringers & Stair Tread ..... 09

Mid Transoms ..... 10

Side Bracket ..... 11

Screw Jack w/ baseplate ..... 12

Swivel Screw Jack w/ baseplate ..... 12

Ladders ..... 13

---

ENGINEERING INFORMATION

---

System Scaffolding Specifications ..... 15

Ledgers ..... 16

Standards ..... 17

Bay Brace ..... 18

Side Bracket ..... 19

## STANDARDS

MODEL NO.	DESCRIPTION	WEIGHT		EFFECTIVE LENGTH		OVERALL WIDTH	
		lbs	kg	in	m	in	Length
SDBSC	Base Collar	4	1.82	7.8	0.2	13.75	0.35
SDSTD.5M	0.5M Standard	7	3.18	19.7	0.5	25.6	0.65
SDSTD1M	1M Standard	12	5.45	39.4	1	45.25	1.15
SDSTD1.5M	1.5M Standard	17.5	7.95	59	1.5	65	1.65
SDSTD2M	2M Standard	23	10.45	78.75	2	84.6	2.15
SDSTD3M	3M Standard	33.5	15.23	118	3	124	3.15

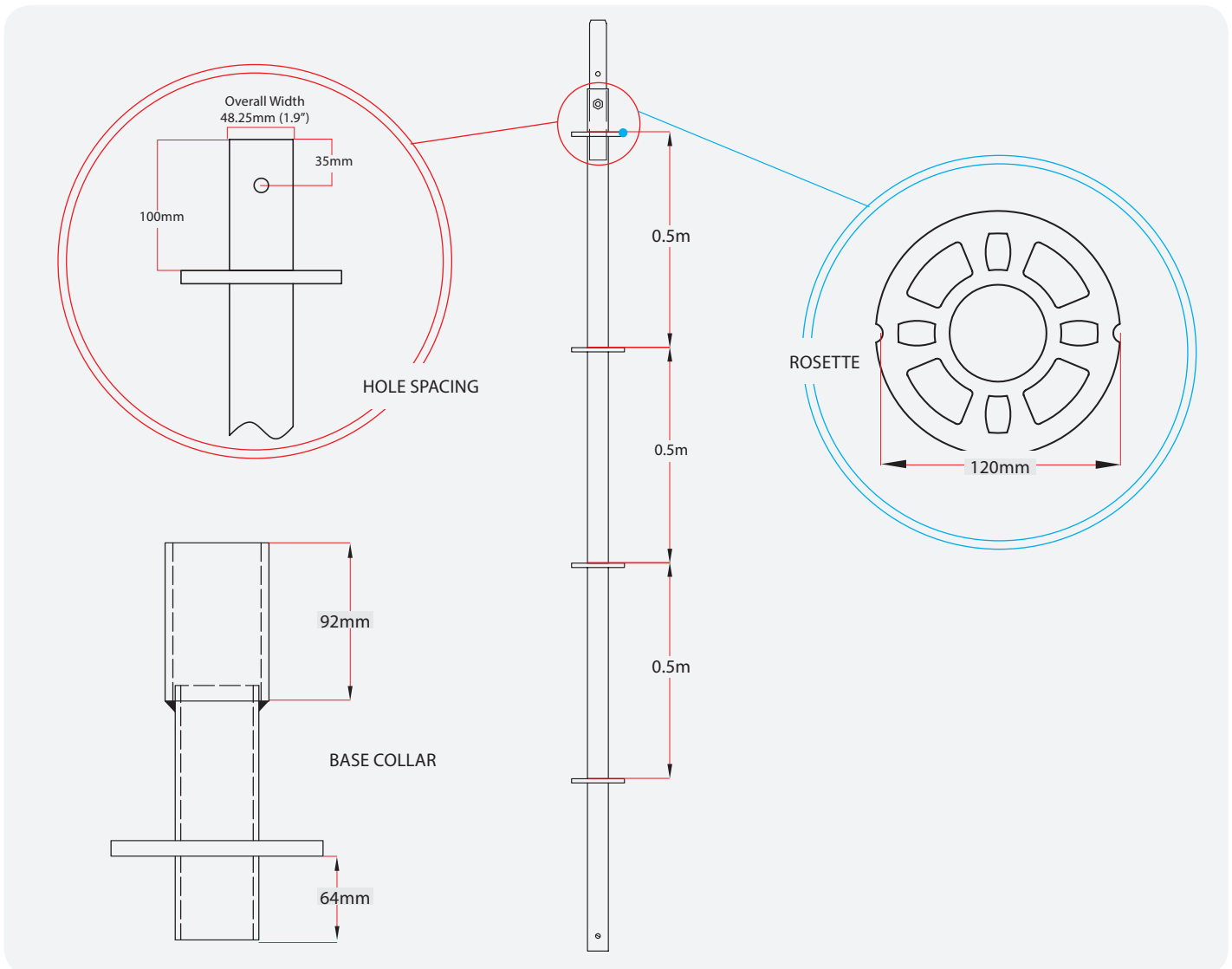

## LEDGERS

PART NO.	DESCRIPTION	WEIGHT		NET LENGTH		OVERALL WIDTH		STANDARD SPACING WIDTH	
		lbs	kgs	in	m	in	m	in	m
SDLED.65M	0.65M Ledger	7.5	3.41	18.9	0.48	23.6	0.6	25.6	0.65
SDLED.88M	0.88M Ledger	9.5	4.32	28	0.71	32.7	0.83	34.6	0.88
SDLED3'6"	3' 6" Ledger	11	5.00	35.4	0.9	40.2	1.02	42	1.067
SDLED1.15M	1.15M Ledger	11.5	5.23	38.6	0.98	43.3	1.1	45.275	1.15
SDLED4	4' Ledger	12	5.45	40.5	1.03	45.3	1.15	48	1.2
SDLED5	5' Ledger	15	6.82	52.4	1.33	57	1.45	60	1.5
SDLED1.57M	1.57M Ledger	15	6.82	55	1.4	59.8	1.52	61.8	1.57
SDLED2.13M	2.13M Ledger	20	9.09	78	1.98	81.9	2.08	84	2.13
SDLED8	8' Ledger	22.5	10.23	89.4	2.27	94.5	2.4	96	2.44
SDLED3.05M	3.05M Ledger	27.5	12.50	114.2	2.9	118	3	120	3.05

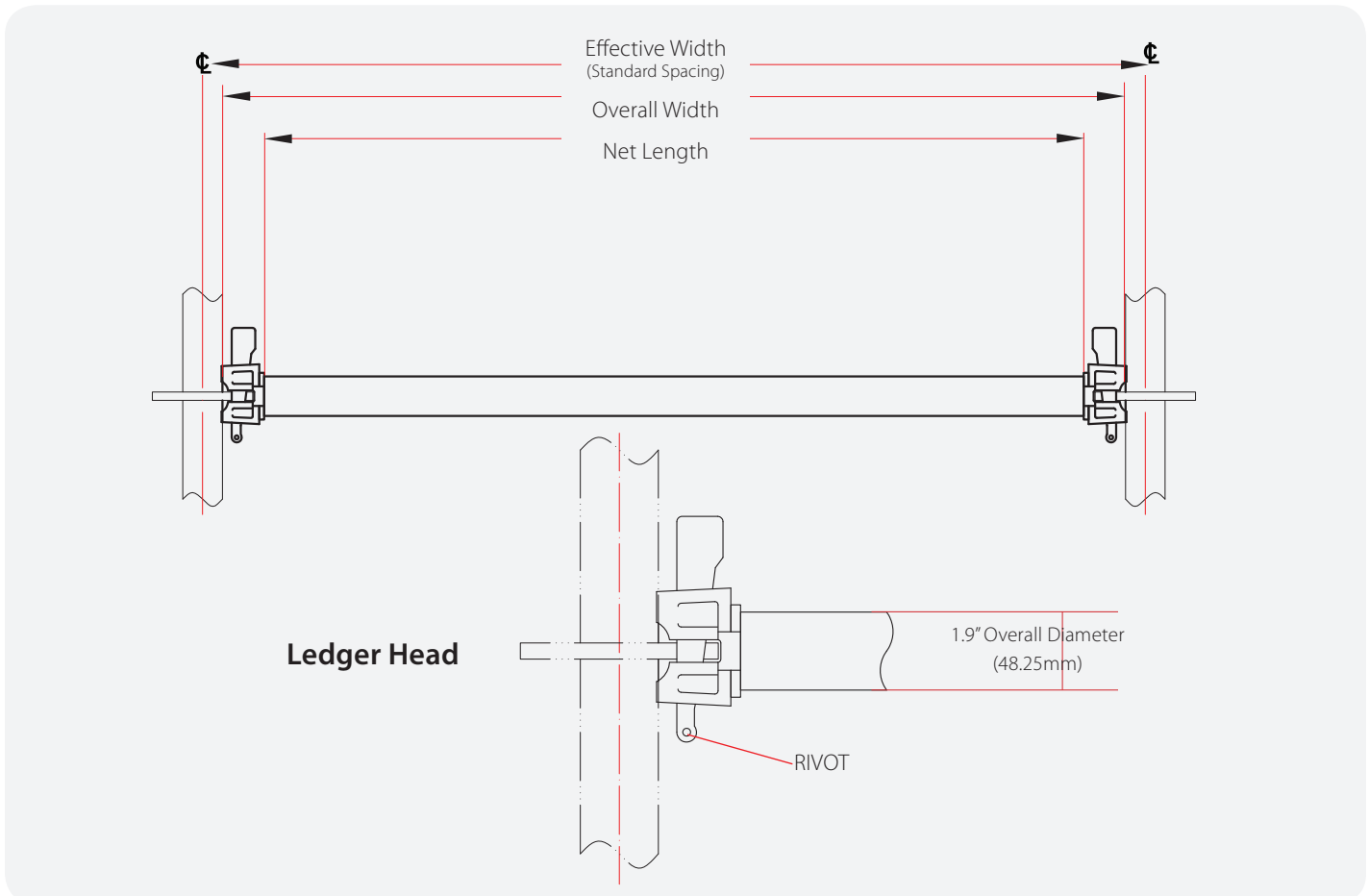

## TRUSS LEDGERS

PART NO.	DESCRIPTION	STANDARD SPACING		OVERALL WIDTH		NET WIDTH		WEIGHT	
		in	m	in	m	lbs	kgs	lbs	kgs
SDTL2.13M	2.13M Truss Ledger	84	2.13	82.1	2.09	78.5	1.99	30	9.09
SDTL8	8' Truss Ledger	96	2.44	94.1	2.39	90.5	2.30	35	10.23
SDTL3.05M	3.05M Truss Ledger	120	3.05	118.1	3.00	114.5	2.91	45	12.50

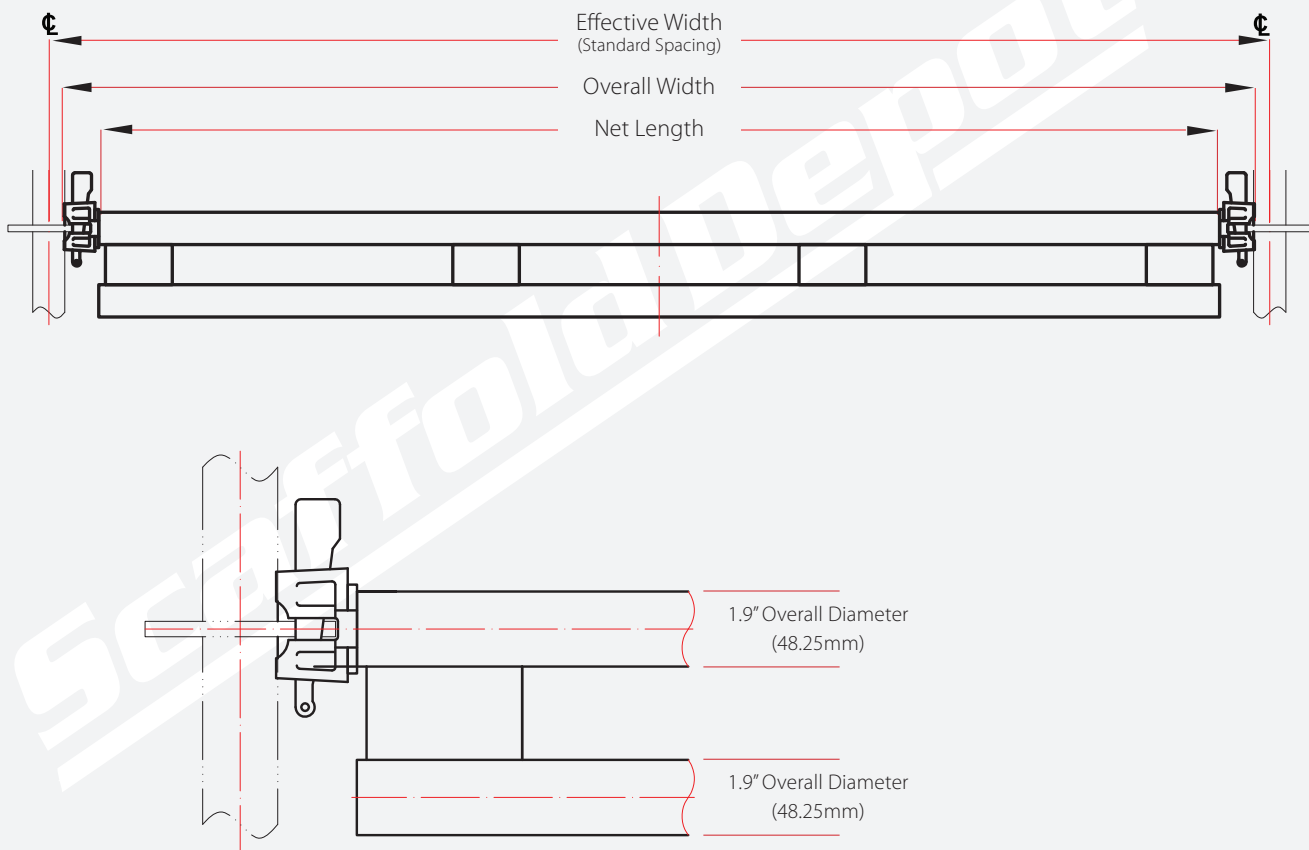

## LATTICE GIRDERS

PART NO.	DESCRIPTION	STANDARD SPACING		OVERALL WIDTH		NET WIDTH		WEIGHT	
		in	m	in	m	in	m	lbs	kgs
SDLG4.26M	4.26M (14') Lattice Girder	168	4.27	166.1	4.22	162.5	4.13	99	45.00
SDLG5.18M	5.18M (17') Lattice Girder	204	5.18	202.1	5.13	198.5	5.04	119	54.09
SDLG6.39M	6.39M (21') Lattice Girder	252	6.40	250.1	6.35	246.5	6.25	144	65.45
SDLG8.52M	8.52M (28') Lattice Girder	336	8.53	334.1	8.49	330.5	8.39	195	88.64

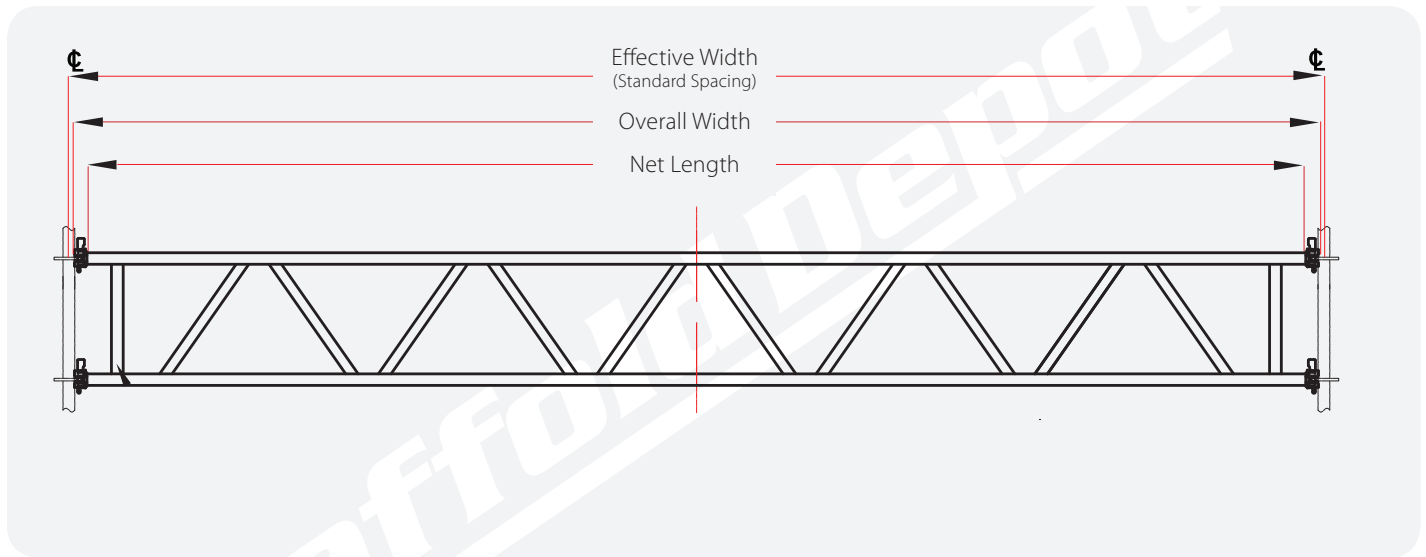

## BAY BRACES

PART NO.	DESCRIPTION	WEIGHT		EFFECTIVE WIDTH		OVERALL WIDTH		BOLT SPACING	
		lbss	kgs	in	m	in	m	in	m
SDBB1.15	1.15M Baybrace	22.5	10.23	45.27	1.15	93	2.4	88	2.2
SDBB1.57	1.57M Baybrace	24.5	11.14	62	1.57	101.5	2.6	96.5	2.5
SDBB2.13	2.13M Baybrace	27.5	12.50	84	2.13	115.7	2.9	110.7	2.8
SDBB8	8' Baybrace	29	13.18	96	2.4	124.5	3.2	119.5	3
SDBB3.05	3.05M Baybrace	33	15.00	120	3.05	143.5	3.6	138.5	3.5

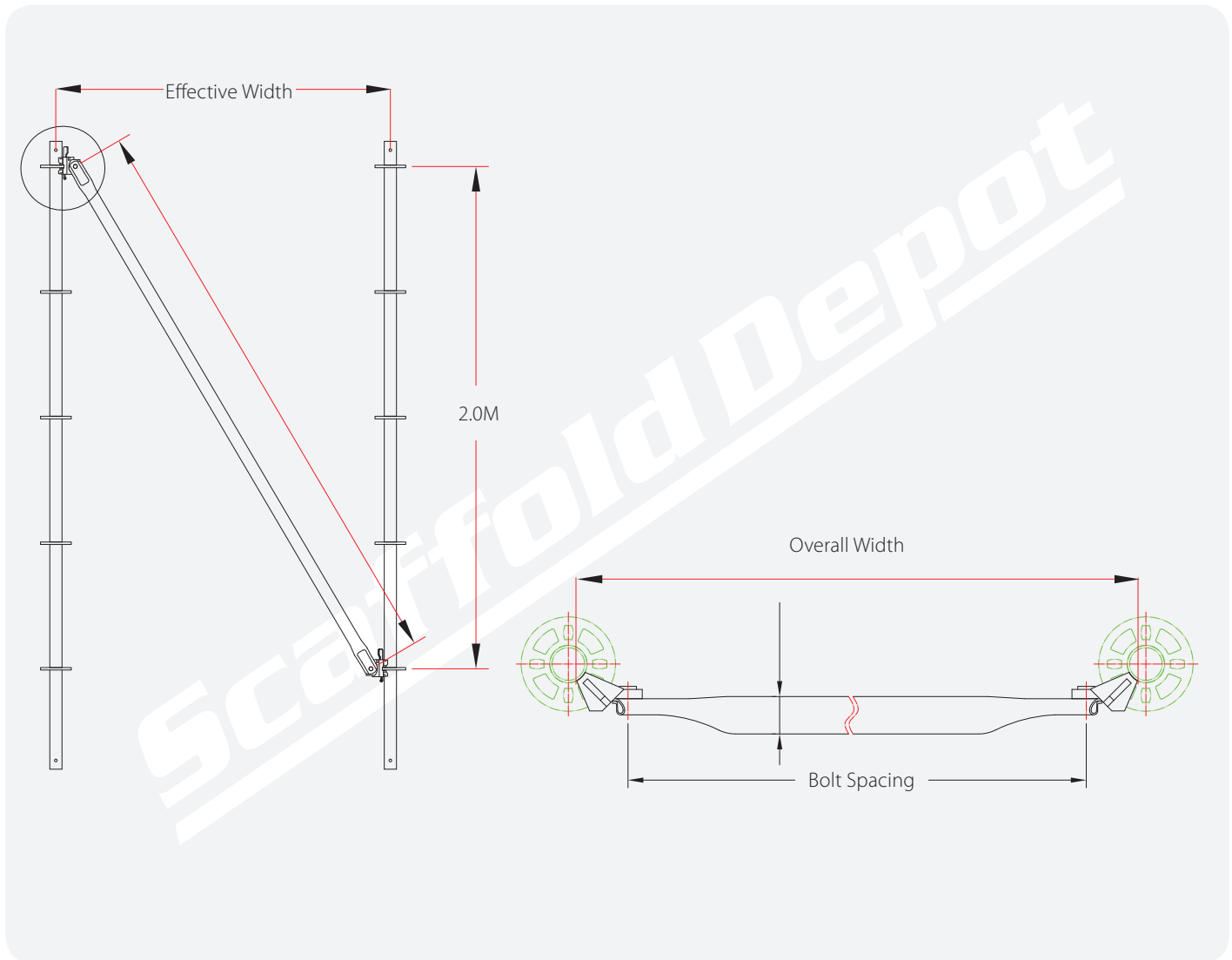



## STAIR STRINGERS

PART NO.	DESCRIPTION	OVERALL LENGTH		STANDARD SPACING		RISE		WEIGHT	
		in	m	in	m	in	m	lbs	kg
SDSS7	7" Stair Stringer	116 3/8	2.96	84	2.13	78.74	2	64	29.09

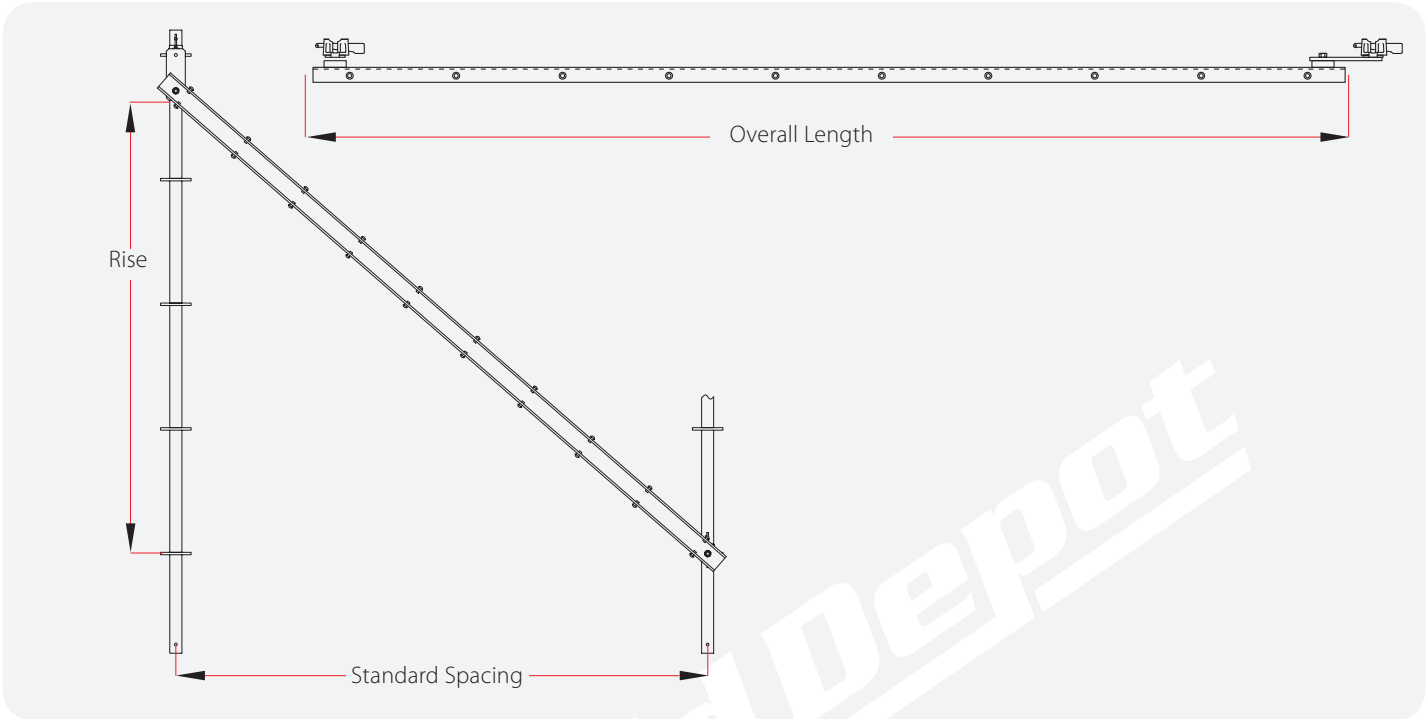

## STAIR TREAD

PART NO.	DESCRIPTION	TREAD DEPTH		TREAD WIDTH		HOLE SPACING		WEIGHT	
		in	m	in	m	in	m	lbs	kgs
SDT32	32" Stair Tread	9.5	0.24	29 1/4	0.74	32 1/4	0.82	16	7.27

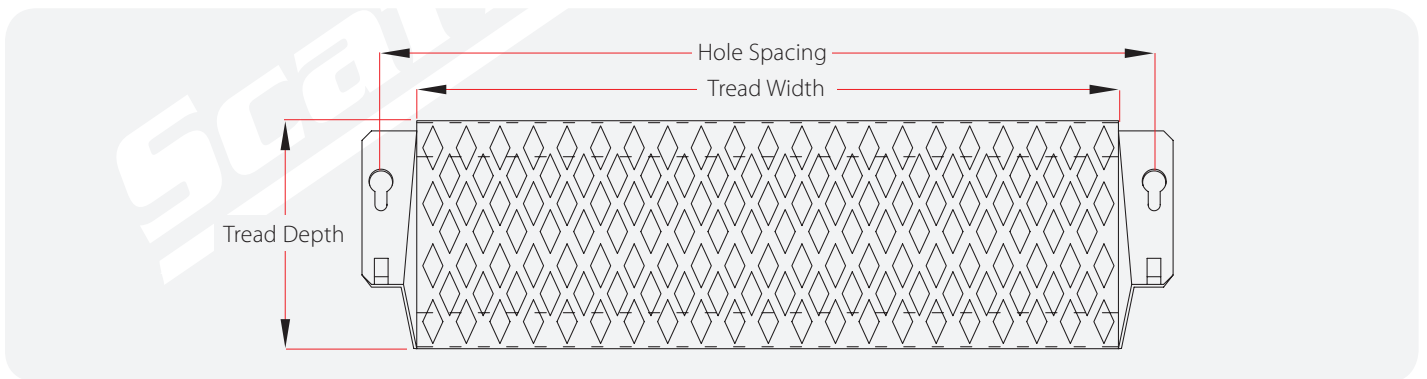

## MID TRANSOMS

PART NO.	DESCRIPTION	STANDARD SPACING		OVERALL WIDTH		STANDARD SPACING		WEIGHT	
		in	m	in	m	in	m	lbs	kg
SDMT.65M	0.65M Mid-Transom	25.6	0.65	28.35	0.72	22.1	0.56	8.65	2.95
SDMT3'6"	3'6" Mid-Transom	42	1.067	44.75	1.14	38.5	0.98	12.511	5.00
SDMT1.15M	1.15M Mid-Transom	45.275	1.15	48.025	1.22	41.775	1.06	13	5.23
SDMT1.57M	1.57M Mid-Transom	61.8	1.57	64.55	1.64	58.3	1.48	16.5	6.25
SDMT2.13M	2.13M Mid-Transom	84	2.13	86.75	2.20	80.5	2.04	21	8.86

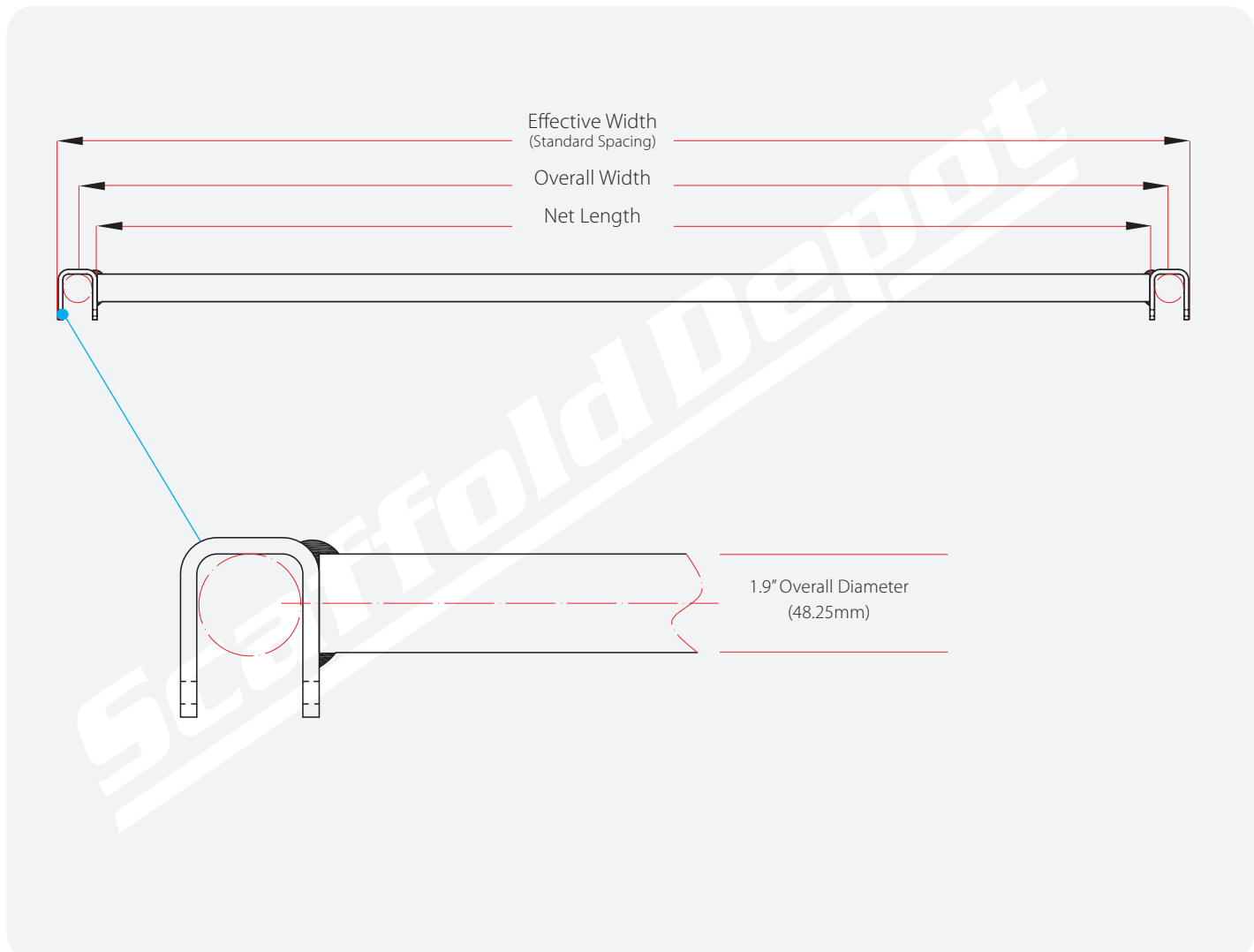

## SIDE BRACKET

PART NO.	DESCRIPTION	Length A		Length B		Weight	
		Overall Width		Net Width		lbs	kgs
		m	in	in	m		
SDSB.4M	0.4M Side Bracket	19.7	0.5	15.45	0.39	11	5.00
SDSB.65M	0.65M Side Bracket	26	0.66	21.75	0.55	15	6.82
SDSB.88M	0.88M Side Bracket	35	0.89	30.75	0.78	17.5	7.95
SDSB1.05M	1.05M Side Bracket	41.7	1.06	37.45	0.95	22	10.00
SDSB1.15M	1.15M Side Bracket	45.7	1.16	41.45	1.05	23	10.45

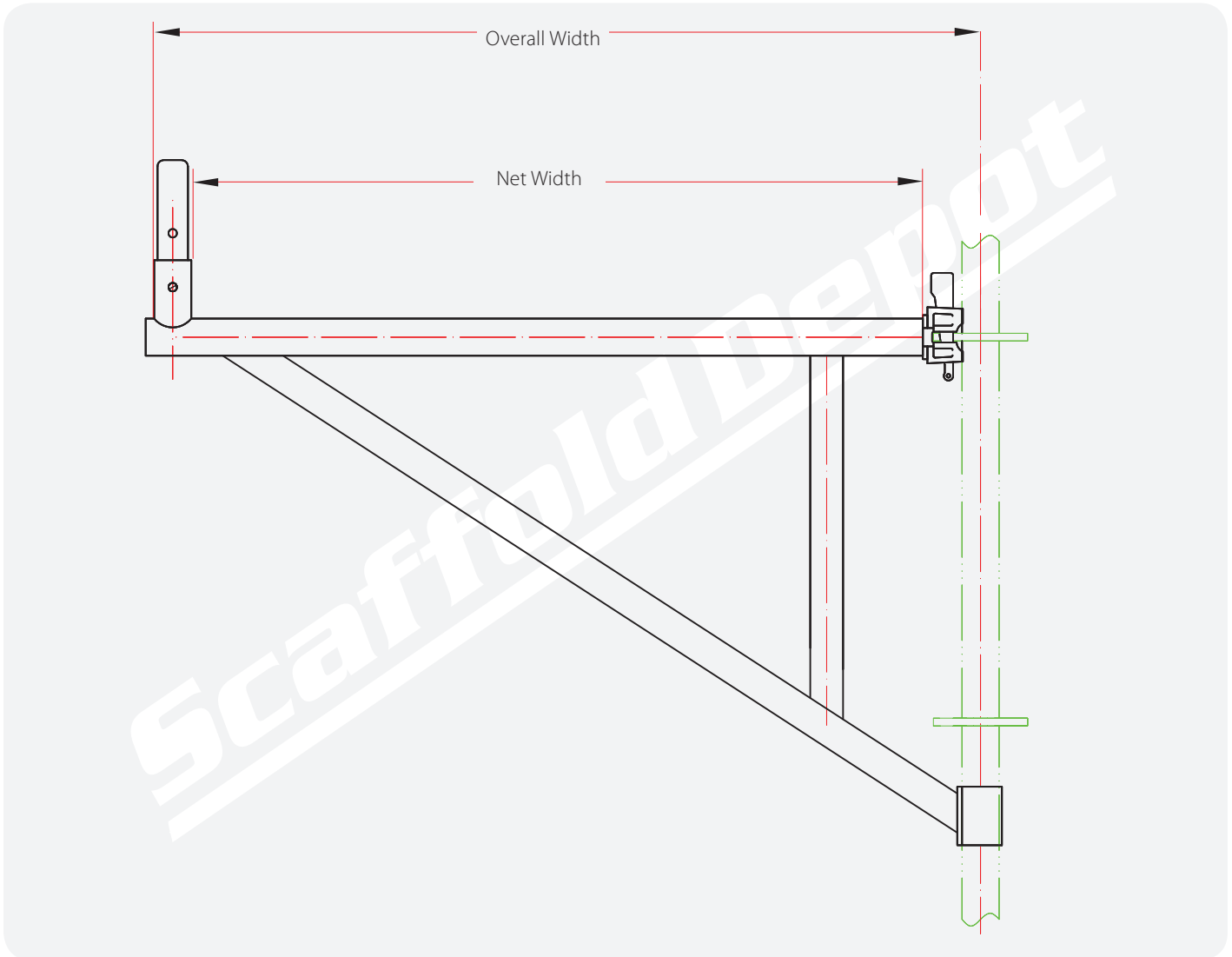

## SCREW JACKS WITH BASE PLATE

PART NO.	DESCRIPTION	ADJUSTMENT RANGE		OVERALL HEIGHT		WEIGHT	
		in	m	in	m	lbs	kgs
SDSJB24	24" Screwjack w/ basplate	1-18		24	0.61	12	5.4
SDSJB36	36" Screwjack w/ baseplate	1-24		36	0.91	16	7.2
SDSWSJ24	24" Swivel Screwjack w/ baseplate	3-18		24	0.61	13	5.9

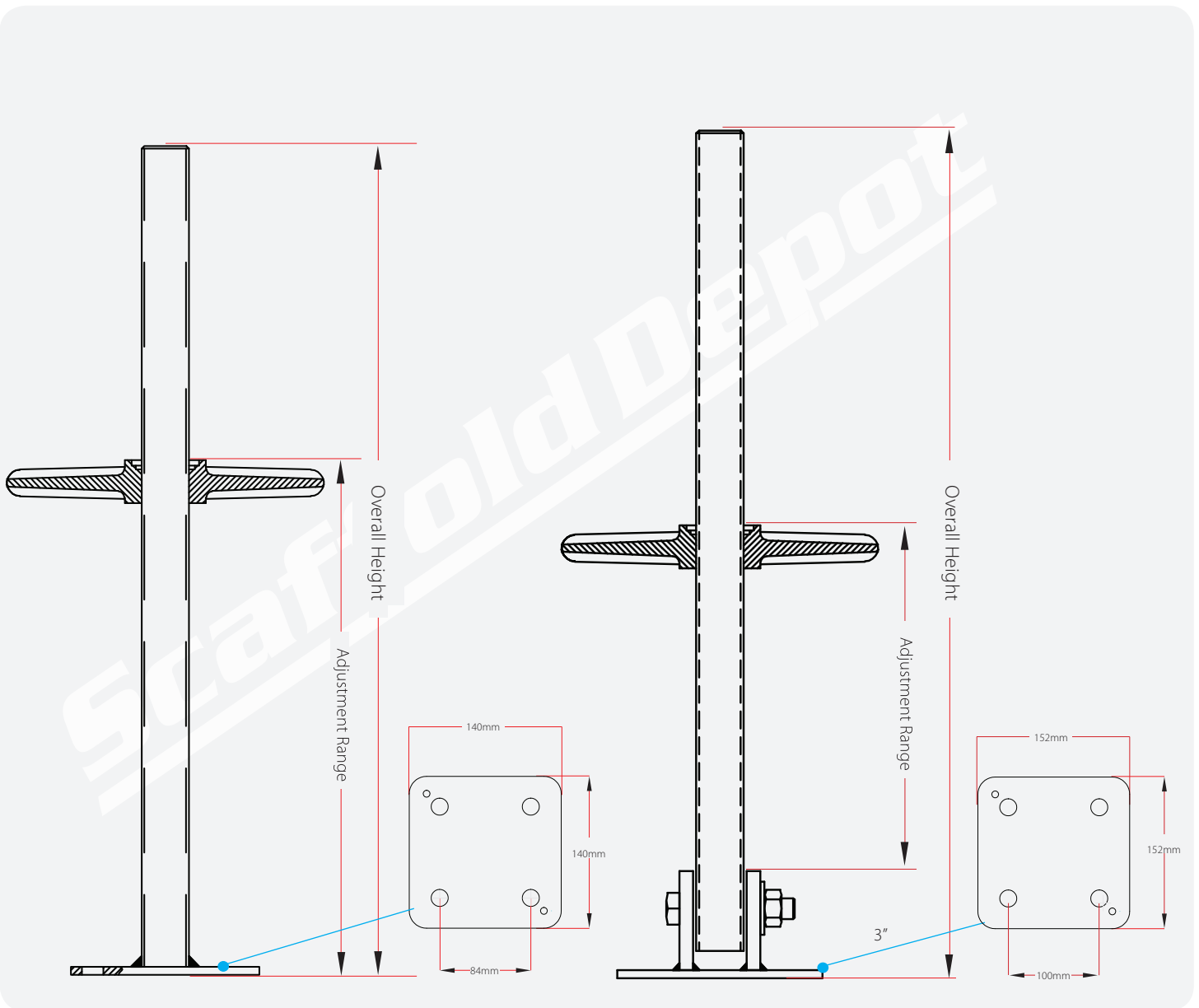

## LADDERS

PART NO.	DESCRIPTION	OVERALL HEIGHT		EFFECTIVE HEIGHT		EFFECTIVE WIDTH		WEIGHT	
		in	m	in	m	in	m	lbs	kgs
LB3	3' Steel Ladder	41	1.04	36	0.910	17	0.44	10	4.32
LB5	5' Steel Ladder	65	1.65	60	1.52	17	0.44	20	6.82
SDAL 5	5' Aluminum Ladder 1.9" O.D.	64.5	1.64	60	1.52	14	0.35	15	6.82
SDAL 10	10' Aluminum Ladder 1.9" O.D.	124.5	3.16	120	3.05	14	0.35	27	11.34
SDSBC	Starter Bracket with Clamp	n/a	n/a	n/a	n/a	17	0.44	9.5	4.08

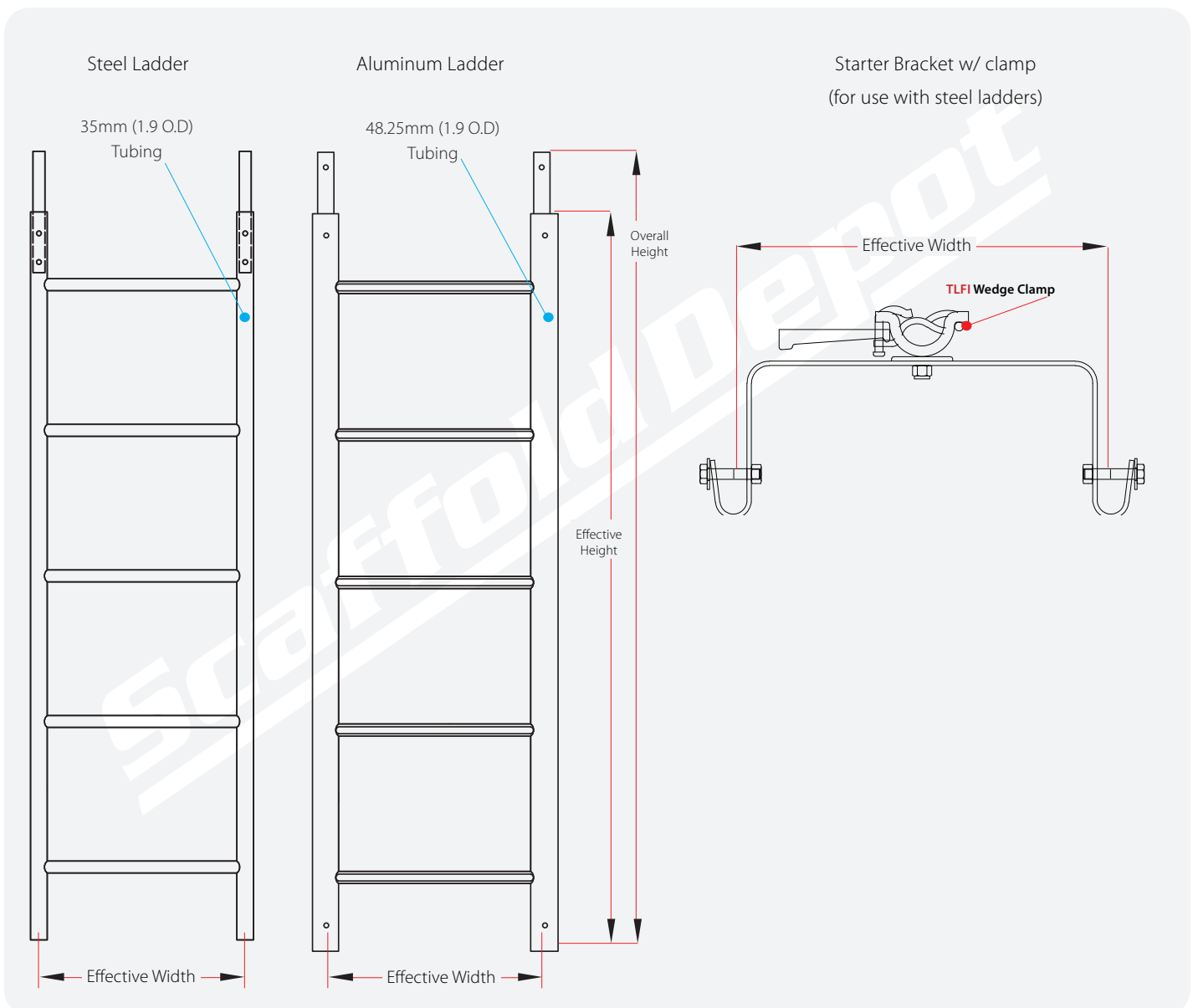

---

---

## ENGINEERING INFORMATION

## SYSTEM SCAFFOLDING MATERIAL SPECIFICATIONS

	item	material	pipe OD and tol.	wt and tol	min yield strength
1	standard	high strength low-alloy steel (Q345)	48.6 +/-0.3MM	3.2 +/-0.20MM	50,000PSI
2	ledger	high strength low-alloy steel (Q345)	48.6 +/-0.3MM	3.2 +/-0.20MM	50,000PSI
3	baybrace	high strength low-alloy steel (Q345)	48.6 +/-0.3MM	3.2 +/-0.20MM	50,000PSI
4	base collar (part a)	high strength low-alloy steel (Q345)	48.6 +/-0.3MM	3.2 +/-0.20MM	50,000PSI
5	base collar (part b)	normal carbon steel (Q235)	60.0 +/-0.4MM	4.5 +/-0.30MM	34,000PSI
6	truss ledger	high strength low-alloy steel (Q345)	48.6 +/-0.3MM	3.2 +/-0.20MM	50,000PSI
7	double truss ledger	high strength low-alloy steel (Q345)	48.6 +/-0.3MM	3.2 +/-0.20MM	50,000PSI
8	side bracket	high strength low-alloy steel (Q345)	48.6 +/-0.3MM	3.2 +/-0.20MM	50,000PSI
9	ledger mouth piece	cast steel			34,000PSI
10	baybrace end piece	cast steel			34,000PSI
11	wedge	normal carbon steel (Q235)			34,000PSI
12	rosette	high strength low-alloy (Q345)			50,000PSI

## LEDGERS

Size		Uniformly Distributed		Concentrated	
Feet	Meters	kN/m	Lb/ft	kN	Lb
2' 2"	0.65	23.43	1785	7.82	1759
2' 10"	0.88	13.34	1016	5.9	1326
3' 6"	1.067	8.17	664	4.77	1072
3' 10"	1.15	7.27	554	4.35	978
4'	1.22	6.68	509	4.17	938
5'	1.52	4.27	325	3.34	751
5' 2"	1.57	4	305	3.23	726
7'	2.13	2.18	166	2.39	536
8'	2.44	1.66	127	2.09	469
10'	3.05	1.06	81	1.67	375

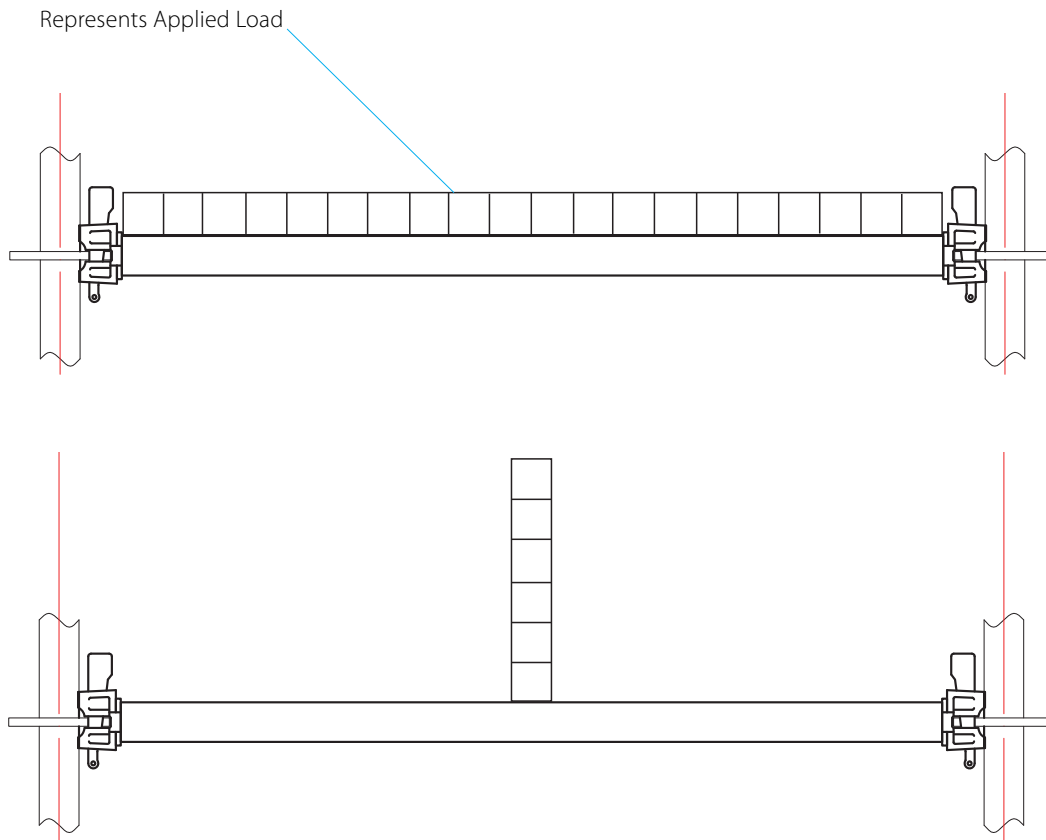



## STANDARDS

Distance "Y"		Capacity	
Feet	Meters	kN	Lb/ft
6' 6"	2.0	22.24	5,000
(MOST TYPICAL)			
4' 11"	1.5	33.36	7,500
3' 3"	1.0	40.03	9,000
9' 10"	3.0	11.12	2,500



## BAY BRACE

Bay Width		Tension		Compression	
Inches	Meters	kN	Lb	kN	Lb
26	0.65	6.45	1450	9.97	2242
46	1.15	6.45	1450	8.48	1907
48	1.22	6.45	1450	8.28	1854
60	1.52	6.45	1450	7.21	1620
62	1.57	6.45	1450	7.05	1584
84	2.13	6.45	1450	5.36	1204
96	2.44	6.45	1450	4.6	1033
120	3.05	6.45	1450	3.42	769

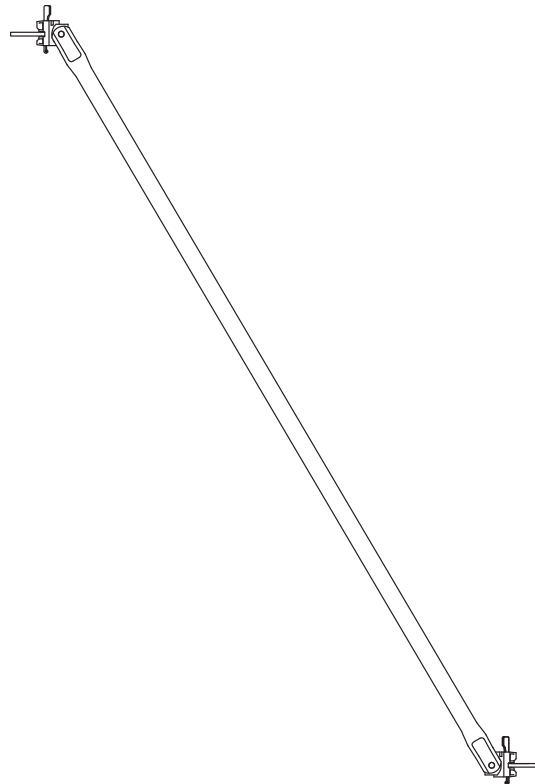

## SIDE BRACKET

Part #	Description	UDL		Point Load	
		(KN)	(lbs)	(KN)	(lbs)
SDSB.65M	0.65m Side Bracket	5.3	1200	2.6	600
SDSB.88M	0.88m Side Bracket	5.3	1200	5.3	600
SDSB1.05M	1.05m Side Bracket	4.4	1000	1.11	250
SOSB1.15M	1.15m Side Bracket	4.4	1000	1.11	250

Based on 4:1 FS

